

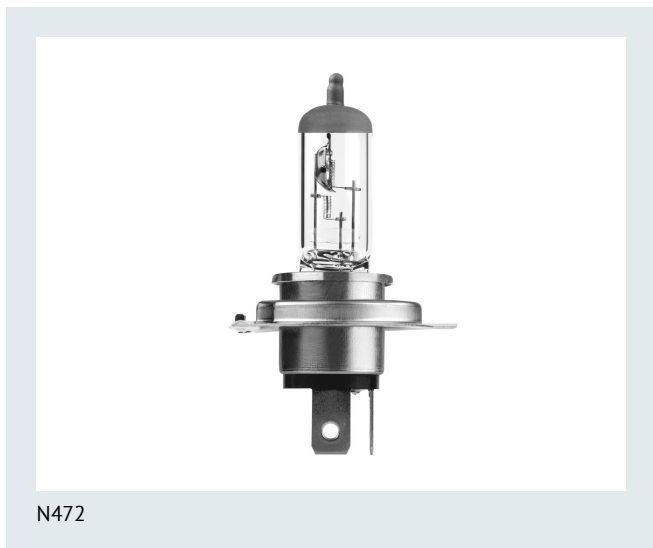

NEOLUX[®]
GERMAN TECHNOLOGY

Standard 60/55 W 12 V P43t

Car lamps from NEOLUX ensure the roads ahead are well-lit and visible to others.



N472

Areas of application

- Headlight



N472



N472-01B

Product information

Application (Category and Product specific)	Halogen headlight lamp
---	------------------------

Electrical Data

Power input	75 W
Test voltage	13.2 V
Nominal voltage	12 V

Photometric Data

Nominal luminous flux	1650/1000 lm
Luminous flux tolerance	±12 %

Physical Attributes & Dimensions

Diameter	17.0 mm
Product weight	23.70 g
Length	82.0 mm
Lamp base	P43t
Diameter	17.0 mm

Lifetime Data

Lifespan Tc	500 hr
Lifespan B3	250 hr

Capabilities

Technology	Halogen lamp
------------	--------------

Certificates & standards

ECE category	H4
British standard	472

Logistical data

Order reference	N472
-----------------	------

Environmental & Regulatory Information

Primary article identifier	4008321771216 4008321756756 4052899198562
Candidate list substance 1	No declarable substances contained
Declaration no. in SCIP database	No declarable substances contained

Packaging Information

Packaging description	EAN	Packaging type	Amount of article
N472	4008321756756	FOLDING BOX	1
N472-01B	4008321771216	BLISTER	1

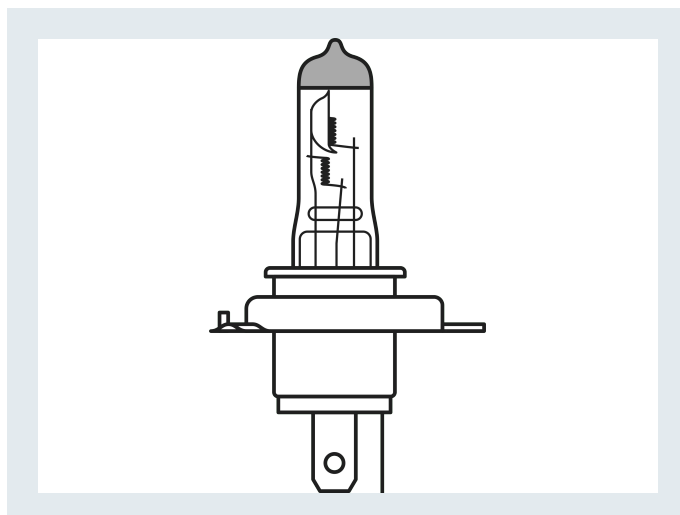

NEOLUX[®]
GERMAN TECHNOLOGY

NEOLUX Automotive Lighting
OSRAM GmbH

Marcel-Breuer-Str 4
80807 Munich, Germany

Phone +49 89 6213-0
Fax +49 89 6213-2020

www.neolux-lighting.com