

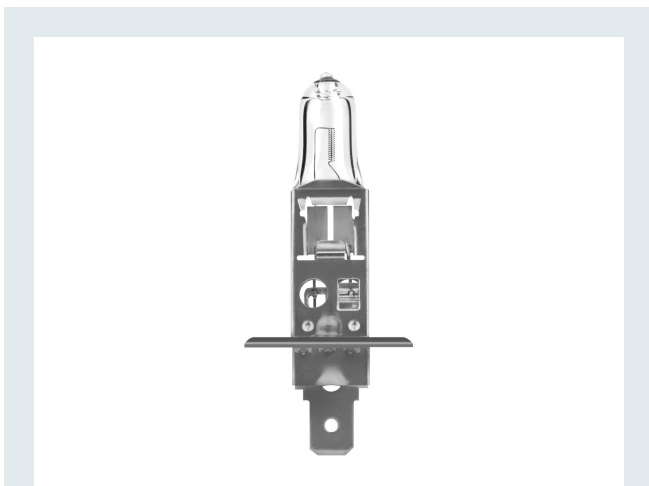

NEOLUX[®]
GERMAN TECHNOLOGY

Extra Light 55 W 12 V P14.5s

Car lamps from NEOLUX ensure the roads ahead are well-lit and visible to others.



N448EL

Product family benefits

- Better visibility
- Remarkable illumination
- Extra light enables drivers to see farther and thereby allows greater reaction time
- Earlier recognition of risks, barriers, and signs
- Affordable

Product family features

- Up to 50 % extra light
- High performance
- More brightness
- ECE certified lamps
- Good and reliable quality thanks to German technology

Areas of application

- Headlight
- Ideal for use in clear-glass headlights

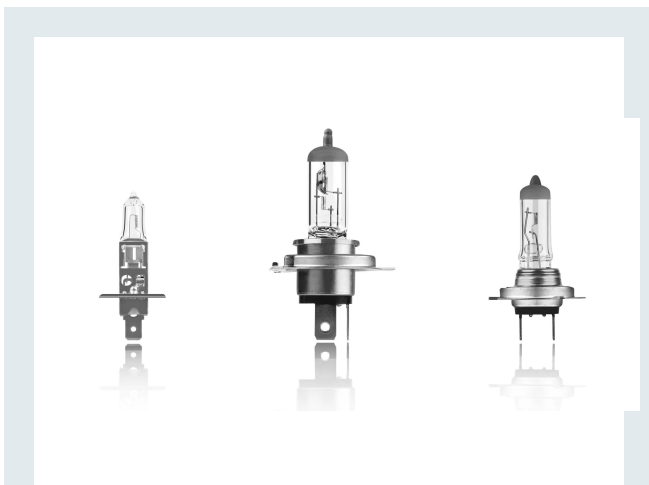

N448EL

Product information

Application (Category and Product specific)	Halogen headlight lamp
---	------------------------

Electrical Data

Power input	68 W
Test voltage	13.2 V
Nominal wattage	55 W
Nominal voltage	12.0 V

Photometric Data

Color temperature	3200 K
Nominal luminous flux	1550 lm
Luminous flux tolerance	±15 %

Physical Attributes & Dimensions

Product weight	6.30 g
Length	62.5 mm
Lamp base	P14.5s
Diameter	8.5 mm

Lifetime Data

Lifespan Tc	350 hr
Lifespan B3	150 hr

Capabilities

Technology	Halogen lamp
------------	--------------

Certificates & standards

ECE category	H1
British standard	448

Logistical data

Order reference	N448EL
-----------------	--------

Environmental & Regulatory Information

Date of declaration	09-07-2024
Primary article identifier	4052899500952 4052899466418
Candidate list substance 1	No declarable substances contained
Declaration no. in SCIP database	In work

Packaging Information

Packaging description NEOLUX	EAN	Packaging type	Amount of article
N448EL	4052899466432		
N448EL-2SCB	4052899500952	SOFT COVER BOX	2

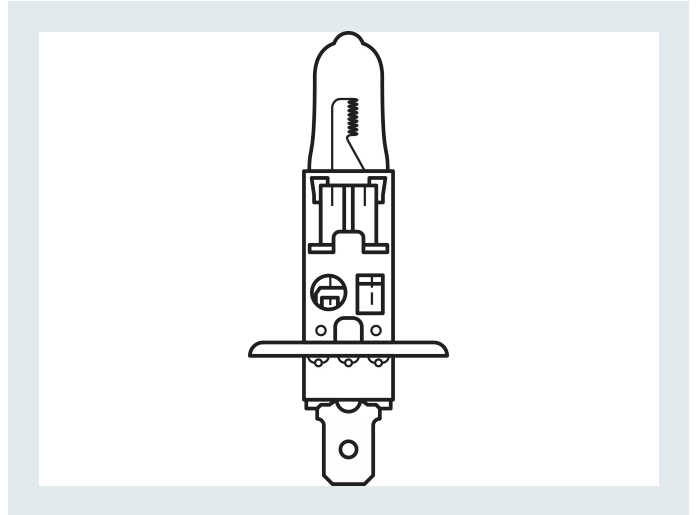

Legal advice

Compared to minimum ECE R112/R37 requirements

NEOLUX[®]
GERMAN TECHNOLOGY

NEOLUX Automotive Lighting
OSRAM GmbH

Marcel-Breuer-Str 4
80807 Munich, Germany

Phone +49 89 6213-0
Fax +49 89 6213-2020

www.neolux-lighting.com