

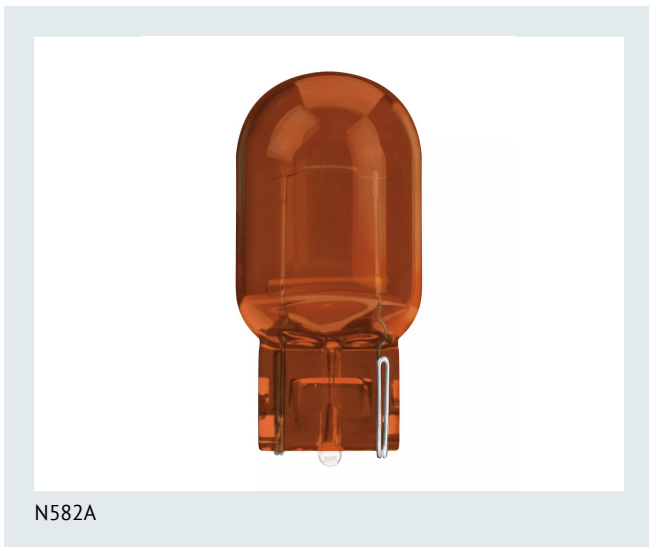

NEOLUX[®]
GERMAN TECHNOLOGY

Standard 21 W 12 V W3x16d

Whether you're a passionate biker or an occasional rider – NEOLUX always has the right lamp to enhance your riding experience. Thanks to technology specifically developed for motorcycles, NEOLUX motorcycle lamps with halogen technology are vibration-resistant.



N582A

Areas of application

- Position and parking light
- Indicator, brake, fog and reversing lights
- Number plate and side position lights
- Interior lighting and reading lights
- Instrument and switch lighting



N582A

Product information

Application (Category and Product specific)	Auxiliary lamp
---	----------------

Electrical Data

Power input	25 W
Test voltage	13.5 V
Power input tolerance	±6 %
Nominal wattage	21 W
Nominal voltage	12 V

Photometric Data

Nominal luminous flux	280 lm
Luminous flux tolerance	±20 %

Physical Attributes & Dimensions

Diameter	20.0 mm
Product weight	6.00 g
Length	47.5 mm
Lamp base	WX3x16d
Diameter	20.0 mm

Lifetime Data

Lifespan Tc	600 hr
Lifespan B3	400 hr

Certificates & standards

ECE category	WY21W
--------------	-------

Logistical data

Order reference	N582A
-----------------	-------

Environmental & Regulatory Information

Primary article identifier	4052899276512
Candidate list substance 1	No declarable substances contained
Declaration no. in SCIP database	No declarable substances contained

Packaging Information

Packaging description	EAN	Packaging type	Amount of article
NEOLUX N582A	4052899276512	UNPACKED (UNPACKED SELLING UNIT FOR END USERS)	1

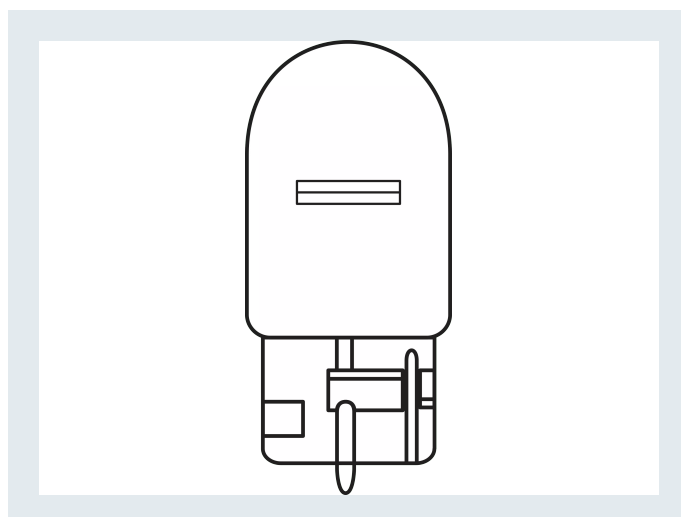

NEOLUX[®]
GERMAN TECHNOLOGY

NEOLUX Automotive Lighting
OSRAM GmbH

Marcel-Breuer-Str 4
80807 Munich, Germany

Phone +49 89 6213-0
Fax +49 89 6213-2020

www.neolux-lighting.com